

JVC

SERVICE MANUAL

COLOR TELEVISION

BASIC CHASSIS

GA2

AV-21F1P (PH)

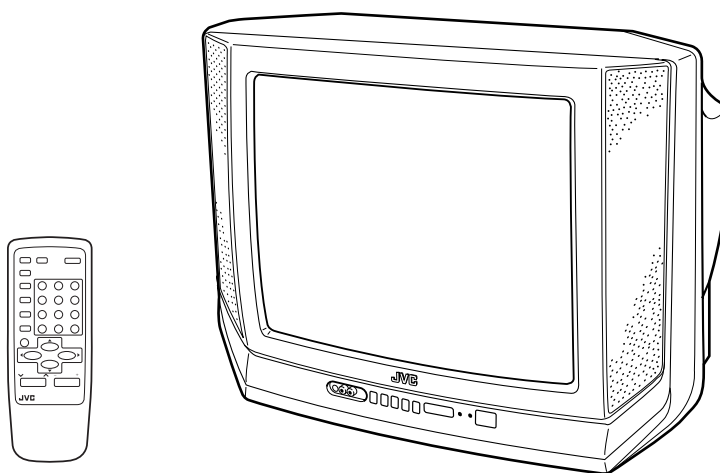

CONTENTS

■ SPECIFICATIONS	2
■ SAFETY PRECAUTIONS	3
■ FEATURES	4
★ OPERATING INSTRUCTIONS (APPENDED)	1-1
■ SPECIFIC SERVICE INSTRUCTIONS	4
■ SERVICE ADJUSTMENTS	10
★ STANDARD CIRCUIT DIAGRAM (APPENDED)	2-1
■ PARTS LIST	27

SPECIFICATIONS

Item	Content	
Dimensions (W × H × D)	619mm × 458mm × 486.5mm	
Mass	22kg	
TV RF System	CCIR (M) & (N)	
Color System	NTSC / PAL-M / PAL-N	
TV Receiving Channel and Frequency		
VHF (VL) Band	(02 ~ 06) 54MHz ~ 88MHz	
VHF (VH) Band	(07 ~ 13) 174MHz ~ 216MHz	
UHF Band	(14 ~ 69) 470MHz ~ 806MHz	
CATV Receiving Channel and Frequency		
Low Band	(02 ~ 06)	
High Band	(07 ~ 13)	
Mid Band	(14 ~ 22)	
Super Band	(23 ~ 36)	
Hyper Band	(37 ~ 64)	
Ultra Band	(65 ~ 94, 100 ~ 125)	
Sub Mid Band	(01, 96 ~ 99)	
	(54MHz ~ 804MHz)	
TV/CATV Total Channel	180 Channels	
Intermediate Frequency		
VIF Carrier	45.75MHz	
SIF Carrier	41.25MHz (4.5MHz)	
Color Sub Carrier Frequency	NTSC: 3.579545MHz PAL-M: 3.57561149MHz PAL-N: 3.58205625MHz	
Aerial Input Terminal	75Ω Unbalanced	
Power Input	Rating: AC110 ~ 240V, 50/60Hz Operating: AC90 ~ 260V, 50/60Hz	
Power Consumption	66W	
Picture Tube	Visible size : 51cm measured diagonally	
High Voltage	26.5kV ± 1kV (at zero beam current)	
Speaker	6cm × 12 cm Oval type × 2	
Audio Output	2W (Monaural)	
Input	Video	1Vp-p, 75Ω
	Audio	500mVrms (−4dBs), High impedance
Output	Video	1Vp-p, 75Ω
	Audio	500mVrms (−4dBs), Low impedance
Headphone Jack	Stereo mini jack (3.5ø)	
Remote Control Unit	RM-C372-1H (Battery size : AA/R06/UM-3 × 2)	

Design & specifications are subject to change without notice.

SAFETY PRECAUTIONS

- The design of this product contains special hardware, many circuits and components specially for safety purposes. For continued protection, no changes should be made to the original design unless authorized in writing by the manufacturer. Replacement parts must be identical to those used in the original circuits. Service should be performed by qualified personnel only.
- Alterations of the design or circuitry of the products should not be made. Any design alterations or additions will void the manufacturer's warranty and will further relieve the manufacturer of responsibility for personal injury or property damage resulting therefrom.
- Many electrical and mechanical parts in the products have special safety-related characteristics. These characteristics are often not evident from visual inspection nor can the protection afforded by them necessarily be obtained by using replacement components rated for higher voltage, wattage, etc. Replacement parts which have these special safety characteristics are identified in the parts list of Service manual. **Electrical components having such features are identified by shading on the schematics and by (Δ) on the parts list in Service manual.** The use of a substitute replacement which does not have the same safety characteristics as the recommended replacement part shown in the parts list of Service manual may cause shock, fire, or other hazards.
- Don't short between the LIVE side ground and ISOLATED (NEUTRAL) side ground or EARTH side ground when repairing.**
Some model's power circuit is partly different in the GND. The difference of the GND is shown by the LIVE : (⊥) side GND, the ISOLATED (NEUTRAL) : (↗) side GND and EARTH : (⊕) side GND. Don't short between the LIVE side GND and ISOLATED (NEUTRAL) side GND or EARTH side GND and never measure with a measuring apparatus (oscilloscope etc.) the LIVE side GND and ISOLATED (NEUTRAL) side GND or EARTH side GND at the same time.
If above note will not be kept, a fuse or any parts will be broken.
- If any repair has been made to the chassis, it is recommended that the B1 setting should be checked or adjusted (See ADJUSTMENT OF B1 POWER SUPPLY).
- The high voltage applied to the picture tube must conform with that specified in Service manual. Excessive high voltage can cause an increase in X-Ray emission, arcing and possible component damage, therefore operation under excessive high voltage conditions should be kept to a minimum, or should be prevented. If severe arcing occurs, remove the AC power immediately and determine the cause by visual inspection (incorrect installation, cracked or melted high voltage harness, poor soldering, etc.). To maintain the proper minimum level of soft X-Ray emission, components in the high voltage circuitry including the picture tube must be the exact replacements or alternatives approved by the manufacturer of the complete product.
- Do not check high voltage by drawing an arc. Use a high voltage meter or a high voltage probe with a VTVM. Discharge the picture tube before attempting meter connection, by connecting a clip lead to the ground frame and connecting the other end of the lead through a 10kΩ 2W resistor to the anode button.
- When service is required, observe the original lead dress. Extra precaution should be given to assure correct lead dress in the high voltage circuit area. Where a short circuit has occurred, those components that indicate evidence of overheating should be replaced. Always use the manufacturer's replacement components.

9. Isolation Check

(Safety for Electrical Shock Hazard)

After re-assembling the product, always perform an isolation check on the exposed metal parts of the cabinet (antenna terminals, video/audio input and output terminals, Control knobs, metal cabinet, screw heads, earphone jack, control shafts, etc.) to be sure the product is safe to operate without danger of electrical shock.

(1) Dielectric Strength Test

The isolation between the AC primary circuit and all metal parts exposed to the user, particularly any exposed metal part having a return path to the chassis should withstand a voltage of 3000V AC (r.m.s.) for a period of one second.

(. . . Withstand a voltage of 1100V AC (r.m.s.) to an appliance rated up to 120V, and 3000V AC (r.m.s.) to an appliance rated 200V or more, for a period of one second.)

This method of test requires a test equipment not generally found in the service trade.

(2) Leakage Current Check

Plug the AC line cord directly into the AC outlet (do not use a line isolation transformer during this check.). Using a "Leakage Current Tester", measure the leakage current from each exposed metal part of the cabinet, particularly any exposed metal part having a return path to the chassis, to a known good earth ground (water pipe, etc.). Any leakage current must not exceed 0.5mA AC (r.m.s.).

However, in tropical area, this must not exceed 0.2mA AC (r.m.s.).

● Alternate Check Method

Plug the AC line cord directly into the AC outlet (do not use a line isolation transformer during this check.). Use an AC voltmeter having 1000 ohms per volt or more sensitivity in the following manner. Connect a 1500Ω 10W resistor paralleled by a 0.15μF AC-type capacitor between an exposed metal part and a known good earth ground (water pipe, etc.). Measure the AC voltage across the resistor with the AC voltmeter. Move the resistor connection to each exposed metal part, particularly any exposed metal part having a return path to the chassis, and measure the AC voltage across the resistor. Now, reverse the plug in the AC outlet and repeat each measurement. Any voltage measured must not exceed 0.75V AC (r.m.s.). This corresponds to 0.5mA AC (r.m.s.).

However, in tropical area, this must not exceed 0.3V AC (r.m.s.). This corresponds to 0.2mA AC (r.m.s.).

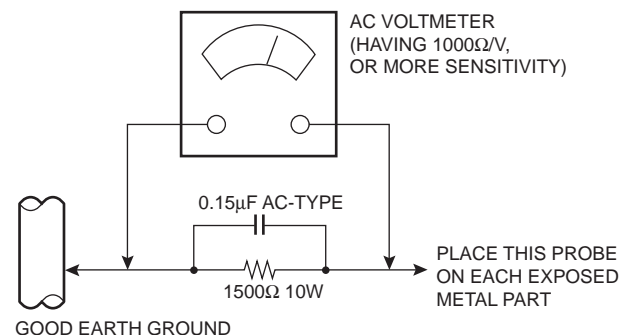

FEATURES

- New chassis design enables use of an interactive on-screen control.
- Wide range voltage for AC power input.
- With AUDIO / VIDEO INPUT & OUTPUT terminals.
- MUTING button can reduce the audio level to zero instantly.
- Functional remote control to operate TV set (for channel select, volume control, power ON/OFF, etc.) from a distance.
- I²C bus is used to control V/C & DEF 1 chip IC, tuner, etc.
- By means of AUTO PROGRAM, the TV stations can be selected automatically and the TV channels can also be rearranged automatically.
- Built-in RETURN +.
- Built-in RTC (real-time clock) enables ON/OFF timer settings.

SPECIFIC SERVICE INSTRUCTIONS

DISASSEMBLY PROCEDURE

REMOVING THE REAR COVER

1. Unplug the AC power cord.
2. Remove the 6 screws marked "A" and 2 screws marked "B".
3. Withdraw the rear cover backward.

REMOVING THE MAIN PW BOARD

- After removing the rear cover.
1. Slightly raise both sides of the Main PW Board by hand and withdraw it backward.
(If necessary, take off the wire clamp, connectors etc.)

REMOVING THE SPEAKER

- After removing the rear cover.
1. Remove the 2 screws marked "C".
 2. Follow the same step for removing the other hand speaker.

CHECKING THE MAIN PW BOARD

To check the back side of the Main PW Board, follow the next steps.

1. Pull out the Main PW Board. (Refer to "REMOVING THE MAIN PW BOARD".)
2. Erect the Main PW Board vertically so that you can easily check its back side.

CAUTION:

- When erecting the Main PW Board, be careful so that there will be no contacting with other PW Board.
- Before turning on power, make sure that all connectors are properly connected.

WIRE CLAMPING AND CABLE TYING

1. Be sure to clamp the wire.
2. Never remove the cable tie used for tying the wires together.
Should it be inadvertently removed, be sure to tie the wires with a new cable tie.

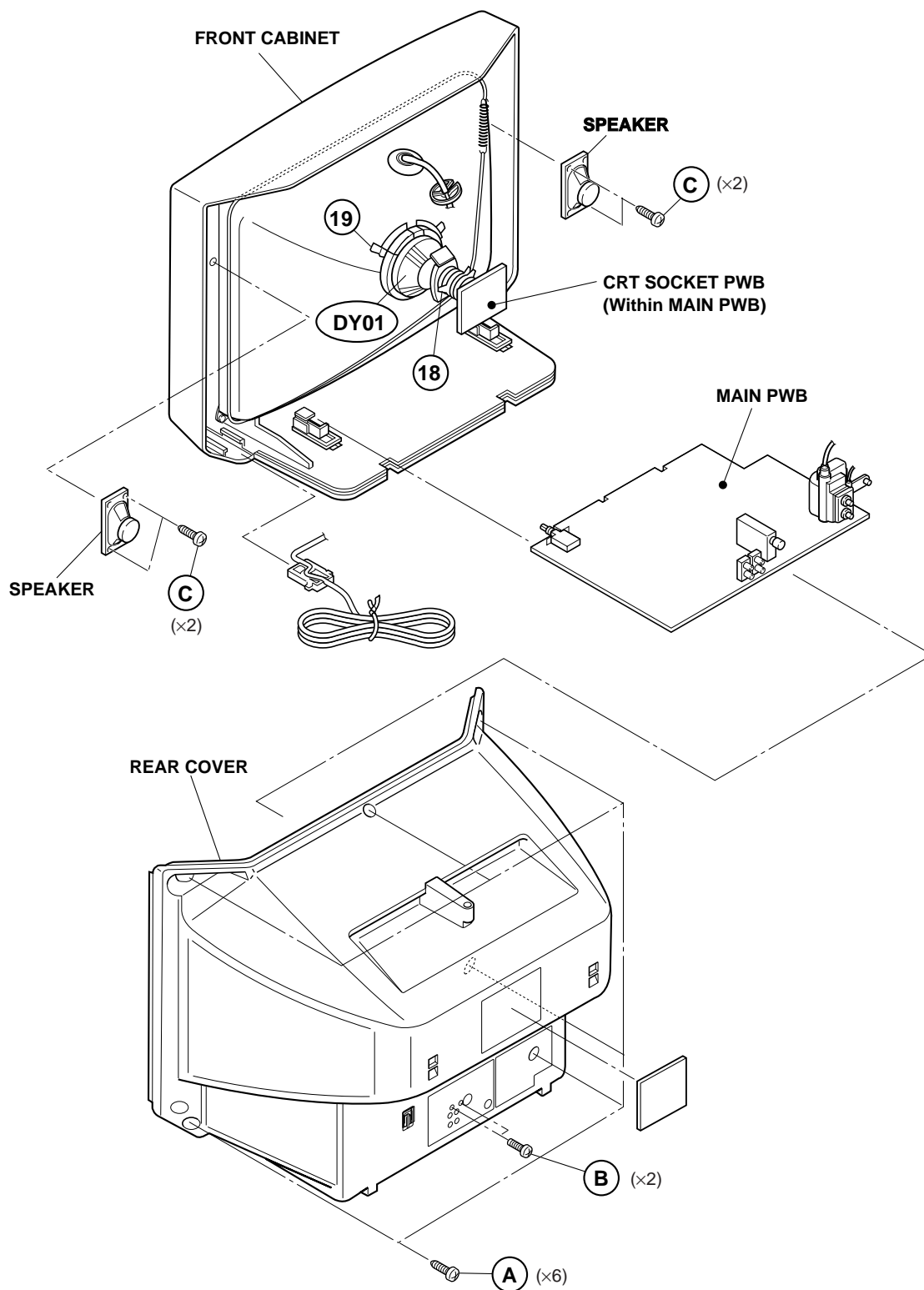

REPLACEMENT OF MEMORY IC

1. MEMORY IC

This TV uses the following memory IC.

Memory IC: IC1704 on MAIN PW Board

The memory IC memorizes data for correctly operating the video and deflection circuits. When replacing the memory IC, be sure to use the same type IC written with the initial values of data. In other words, use the specific IC listed in "PRINTED WIRING BOARD PARTS LIST". For its mounting location, refer to "ADJUSTMENT LOCATIONS".

2. PROCEDURE FOR REPLACING MEMORY IC

(1) Power off

Switch the power off and unplug the power cord from the wall outlet.

(2) Replacing the memory IC

Replace the memory IC with new one. Be sure to use the memory IC written with the initial data values.

(3) Power on

Plug the power cord into the wall outlet and switch the power on.

(4) Check and setting of SYSTEM CONSTANT SET:

- 1) Press the DISPLAY key and the VIDEO STATU key on the remote control unit simultaneously. The SERVICE MENU screen will be displayed. (See Fig. 1.)
- 2) In the SERVICE MENU, again press the DISPLAY key and the VIDEO STATU key simultaneously. Then, the SYSTEM CONSTANT SET screen will be displayed. (See Fig. 2.)
- 3) Check whether the setting values of the SYSTEM CONSTANT SET are the same as those indicated in Table 1. If the value is different, select the setting item with the MENU ▲/▼ key, and set the correct value with the MENU ◀/▶ key.
(The selected value will be stored in memory when the MENU ◀/▶ key is released.)
- 4) Press the EXIT key twice to return to the normal screen.

(5) Receive channel setting

Refer to the **OPERATING INSTRUCTIONS** and set the receive channels (channels preset).

(6) User settings

Check the user setting items in Tables 2-1 and 2-2, and if setting value is different, set the correct value.

For setting, refer to the **OPERATING INSTRUCTIONS**.

(7) Setting of SERVICE MENU

Verify the setting for each setting item in the SERVICE MENU. (See Table 3.) If readjustment is necessary, perform adjustment referring to "SERVICE ADJUSTMENTS".

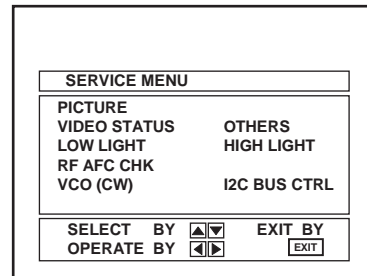

Fig. 1

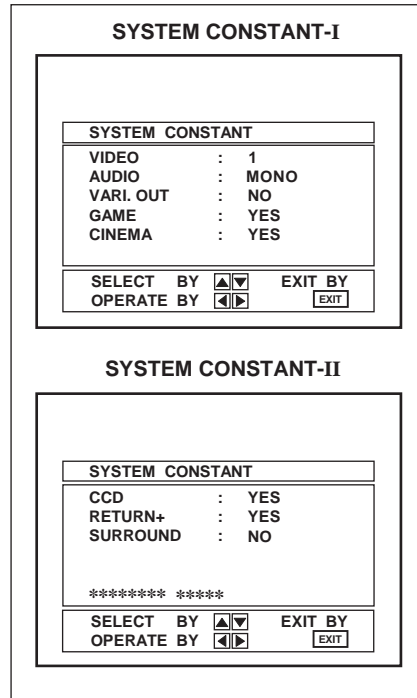
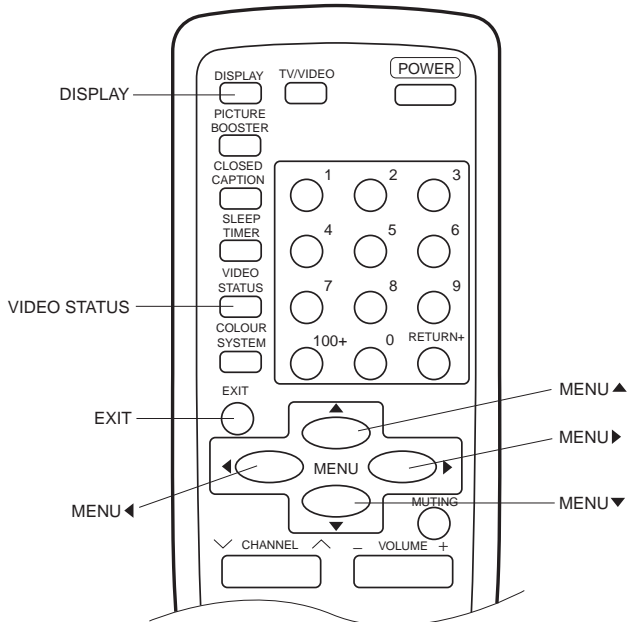

Fig. 2

NAME OF REMOTE CONTROL KEYS



SETTING OF SYSTEM CONSTANT SET

Table 1

Setting item	Setting contents	Setting value
VIDEO	<input type="checkbox"/> 1 <input type="checkbox"/> 2 <input type="checkbox"/>	1
AUDIO	<input type="checkbox"/> MONO <input type="checkbox"/> PH. MONO <input type="checkbox"/> MTS <input type="checkbox"/>	MONO
VARI. OUT	<input type="checkbox"/> YES <input type="checkbox"/> NO <input type="checkbox"/>	NO
GAME	<input type="checkbox"/> YES <input type="checkbox"/> NO <input type="checkbox"/>	YES
CINEMA	<input type="checkbox"/> YES <input type="checkbox"/> NO <input type="checkbox"/>	YES
CCD	<input type="checkbox"/> YES <input type="checkbox"/> NO <input type="checkbox"/>	YES
RETURN+	<input type="checkbox"/> YES <input type="checkbox"/> NO <input type="checkbox"/>	YES
SURROUND	<input type="checkbox"/> YES <input type="checkbox"/> NO <input type="checkbox"/>	NO

USER SETTING VALUES

● Setting of Function

Table 2-1

Setting item	Setting value	Setting item	Setting value
MAIN POWER	OFF	DISPLAY	OFF
SUB POWER	ON	SLEEP TIMER	0
CHANNEL	CH 02	VIDEO STATUS	STANDARD
CHANNEL PRESET	Refer to OPERATING INSTRUCTIONS	CLOSED CAPTION	OFF (CC1/T1)
VOLUME	10	COLOR SYSTEM	AUTO
TV/VIDEO	TV	PICTURE BOOSTER	OFF

● Setting of Menu

Table 2-2

Setting item	Setting value	Setting item	Setting value
TINT	CENTER	SET LOCK CODE	Unnecessary to set
COLOR	CENTER	CHILD LOCK	OFF
PICTURE	CENTER	AUTO TUNER SETUP	AIR
BRIGHT	CENTER	NOISE MUTING	OFF
DETAIL	CENTER	BACKGROUND	BLACK
SET CLOCK	Unnecessary to set	CLOSED CAPTION	CC1 / T1
ON/OFF TIMER	NO	LANGUAGE	ENG.
CHANNEL SUMMARY	Unnecessary to set		

SERVICE MENU SETTING ITEMS

Table 3

Service menu	Setting item	Service menu	Setting item		
PICTURE	1. PICTURE		54. H POS. 60		
	2. BRIGHT		55. H BLK. 60 ← Do not adjust.		
	3. COL. PALM		56. V POS. 60		
	4. COL. PALN		57. V SIZE60		
	5. COL. NTSC		58. V S CR60		
	6. TINT		59. V LIN. 60		
	7. TV DTL	Do not adjust.	60. RF AGC		
	8. EXT PIC.				
	9. EXT BRI.		VIDEO STATUS	TINT	
	10. EXT COL.			COLOR	
	11. EXT TINT			PICTURE	
	12. EXT DTL			BRIGHT	
	13. P/N KILL			DETAIL	
	14. Y S CONT			G DRIVE	
	15. TV Y-DL			B DRIVE	
	16. EXT Y-DL			R CUT.	
	17. WPL SW			G CUT.	
	18. Y GAMMA			B CUT.	
	19. P/N G P.				
	20. COL. L SW			OTHERS	1. OSD HP
	21. COL. LMT.				2. OSD VP
22. PN C. ATT				3. H-CK SW	
23. OFST. SW				Do not adjust.	
24. OFST. B-Y			LOW LIGHT	R CUTOFF	
25. OFST. R-Y				G CUTOFF	
26. C-TOF SW				B CUTOFF	
27. TV T FO			HIGH LIGHT	G DRIVE	
28. TV T Q			B DRIVE		
29. EXT T FO		RF AFC CHK	RF AFC		
30. EXT T Q			FINE		
31. C-TRAP			Do not adjust.		
32. C-TR. FO		VCO (CW)	IF VCO (CW) adjustment mode		
33. C-TRAP Q		I²C BUS CTRL	I ² C BUS		
34. FIX B/W			(Fixed to ON state.)		
35. APA P. FO					
36. DC TRAN.					
37. B. ST. SW					
38. B. ST. PO.					
39. ABL GAIN					
40. ABL PO.					
41. HALF T.					
42. DRV G SW					
43. NT. COMB					
44. COIN DET					
45. NOISE L.					
46. VCD MODE					
47. V AGC SP					
48. H POS. 50					
49. H BLK. 50	← Do not adjust.				
50. V POS. 50					
51. V SIZE50					
52. V S CR50					
53. V LIN. 50					

REPLACEMENT OF CHIP COMPONENT

■ CAUTIONS

1. Avoid heating for more than 3 seconds.
2. Do not rub the electrodes and the resist parts of the pattern.
3. When removing a chip part, melt the solder adequately.
4. Do not reuse a chip part after removing it.

■ SOLDERING IRON

1. Use a high insulation soldering iron with a thin pointed end of it.
2. A 30W soldering iron is recommended for easily removing parts.

■ REPLACEMENT STEPS

1. How to remove Chip parts

● Resistors, capacitors, etc.

- (1) As shown in the figure, while pushing the chip part with tweezers, alternately melt the solder at its each end.

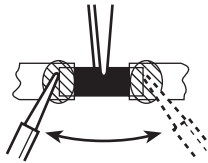

- (2) Shift the chip part with tweezers and remove it.

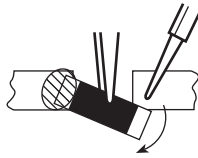

● Transistors, diodes, variable resistors, etc.

- (1) Apply extra solder to each lead.



- (2) As shown in the figure, while pushing the chip part with tweezers, alternately melt the solder at its each lead. Then, shift and remove the chip part.



Note : After removing the part, remove remaining solder from the pattern.

2. How to install Chip parts

● Resistors, capacitors, etc.

- (1) Apply solder to the pattern as indicated in the figure.

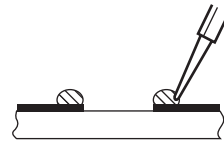

- (2) Grasp the chip part with tweezers and place it on the solder. Then heat and melt the solder at both ends of the chip part.

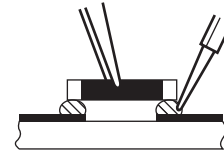

● Transistors, diodes, variable resistors, etc.

- (1) Apply solder to the pattern as indicated in the figure.
- (2) Grasp the chip part with tweezers and place it on the solder.
- (3) First solder lead **A** as indicated in the figure.

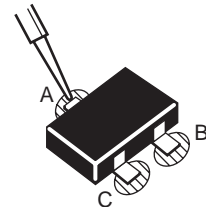

- (4) Then solder leads **B** and **C**.

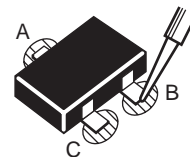

SERVICE ADJUSTMENTS

BEFORE STARTING SERVICE ADJUSTMENT

- There are 2 ways for adjusting this TV: One is with the REMOTE CONTROL UNIT and the other is the conventional method using adjustment parts and components.
- The setting (adjustment) using the REMOTE CONTROL UNIT is made on the basis of the initial setting values. The setting values which adjust the screen to the optimum condition can be different from the initial setting values.
- Make sure that connection is correctly made to AC power source.
- Turn on the power of the TV and measuring instrument for warming up for at least 30 minutes before starting adjustment.
- If the receive or input signal is not specified, use the most appropriate signal for adjustment.
- Never touch parts (such as variable resistors, transformers and capacitors) not shown in the adjustment items of this service adjustment.
- Preparation for adjustment (presetting):
Unless otherwise specified in the adjustment items, preset the following functions with the remote control unit.

Function	Setting value
VIDEO STATUS	STANDARD
TINT, COLOR, PICTURE, BRIGHT DETAIL	CENTER

MEASURING INSTRUMENT AND FIXTURES

- DC voltmeter (or Digital voltmeter)
- Oscilloscope
- Signal generator (Pattern generator)
[PAL / SECAM / NTSC]
- Remote control unit
- TV audio multiplex signal generator
- Frequency counter

ADJUSTMENT/CHECK ITEMS

Adjustment/Check item	Page
B1 POWER SUPPLY Check	16
IF VCO Adjustment	16
RF AGC Adjustment	16
FOCUS Adjustment	16
DEFLECTION CIRCUIT Adjustment	17
VIDEO/CHROMA CIRCUIT Adjustment	18
VIDEO STATUS Adjustment	21
X-RAY PROTECTION Check	22
PURITY, CONVERGENCE Adjustment	23

BASIC OPERATION IN SERVICE MENU

1. TOOL OF SERVICE MENU OPERATION

Operate the SERVICE MENU with the remote control unit.

2. SERVICE MENU ITEMS

With the SERVICE MENU, various settings (adjustments) can be made, and they are broadly classified in the following items of settings:

- PICTURE For entering/adjusting the setting values (adjustment values) of the VIDEO/CHROMA and DEFLECTION circuits.
- VIDEO STATUS For setting the values for CINEMA and GAME.
- OTHERS For setting the values of other items.
- LOW LIGHT For setting the values of WHITE BALANCE circuit.
- HIGH LIGHT For setting the values of WHITE BALANCE circuit .
- RF AFC CHK For checking the RF AFC circuit. **(Do not adjust.)**
- VCO (CW) For adjusting the IF circuit.
- I²C BUS CTRL I²C BUS ON/OFF CONTROL. **(Fixed to ON.)**

3. BASIC OPERATION IN SERVICE MENU

NOTE: In each menu screen, key operation guide will appear at the bottom, which will help your menu operation.

(1) How to enter SERVICE MENU

Press the DISPLAY key and the VIDEO STATUS key on the remote control unit simultaneously.

The SERVICE MENU screen will be displayed. (See Fig. 1.)

- To return to the previous screen, press the EXIT key on the remote control unit.

(2) Selection of Sub Menu Screen

See Fig. 3, menu diagram, on the next page.

- 1) Press the MENU ▲/▼ key on the remote control unit to select an item in the SERVICE MENU screen.
- 2) Enter the Sub Menu as follows:

● Entering "PICTURE" and "OTHERS" Sub Menus

Press the MENU ◀/▶ key in the SERVICE MENU screen. Then, the Screen A shown in Fig. 3 on the next page will appear.

In the Screen A, press the MENU ▲/▼ key to enter the Sub Menu screen.

● Entering other than above Sub Menus

Press the MENU ◀/▶ key in the SERVICE MENU screen. Then, the Sub Menu screen will directly appear.

- To return to the previous screen, press the EXIT key on the remote control unit.

(3) Method of Setting in the Sub Menu Screen

*Once the setting values are set, they are automatically memorized.

1) PICTURE, VIDEO STATUS, OTHERS

- ▲/▼ key: Press to select an item in the Sub Menu.
- ◀/▶ key: Press to select the value of the selected item.
- EXIT key: Press to return to the previous screen.
- VIDEO STATUS key: In the VIDEO STATUS sub menu screen, press to switch between VIDEO STATUS-GAME and VIDEO STATUS-CINEMA.

2) LOW LIGHT, HIGH LIGHT

Setting will be done by using the numeral key on the remote control unit.

3) RF AFC CHK

Do not adjust.

4) VCO (CW)

Setting will be done by adjusting the CW TRANSF. (T111) on the Main PWB.

5) I2C BUS CTRL

Do not adjust. This item should always be fixed to ON to normally operate the TV set.

(4) Release of SERVICE MENU

After completing the setting, repeatedly press the EXIT key until the screen returns to the normal screen.

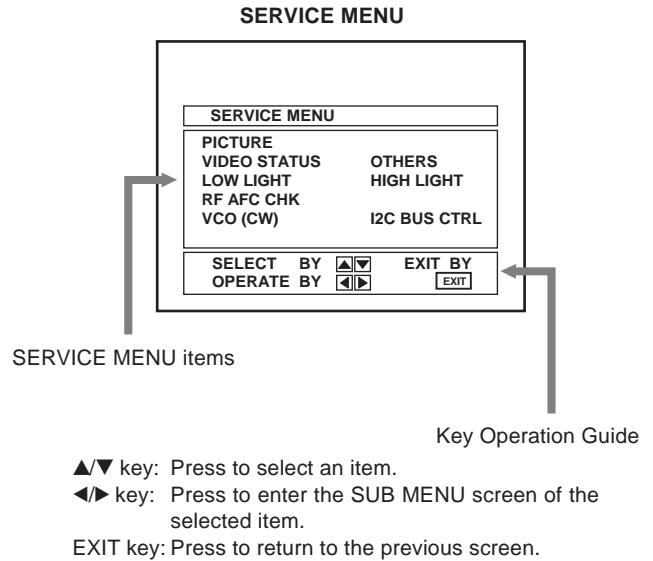

Fig. 1 SERVICE MENU

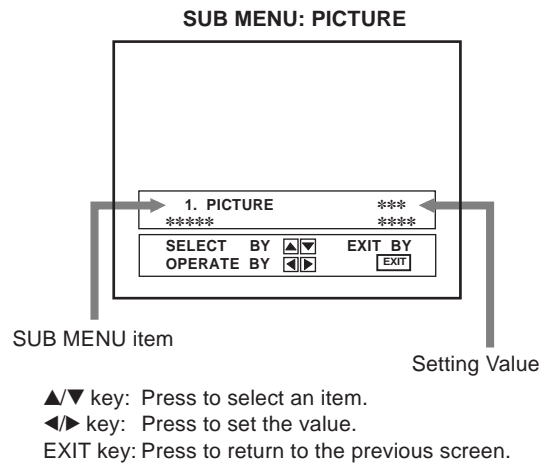
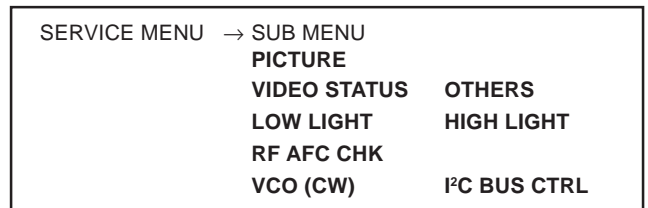

Fig. 2 SUB MENU example (PICTURE)

Fig. 2

SERVICE MENU AND SUB MENU SCREENS

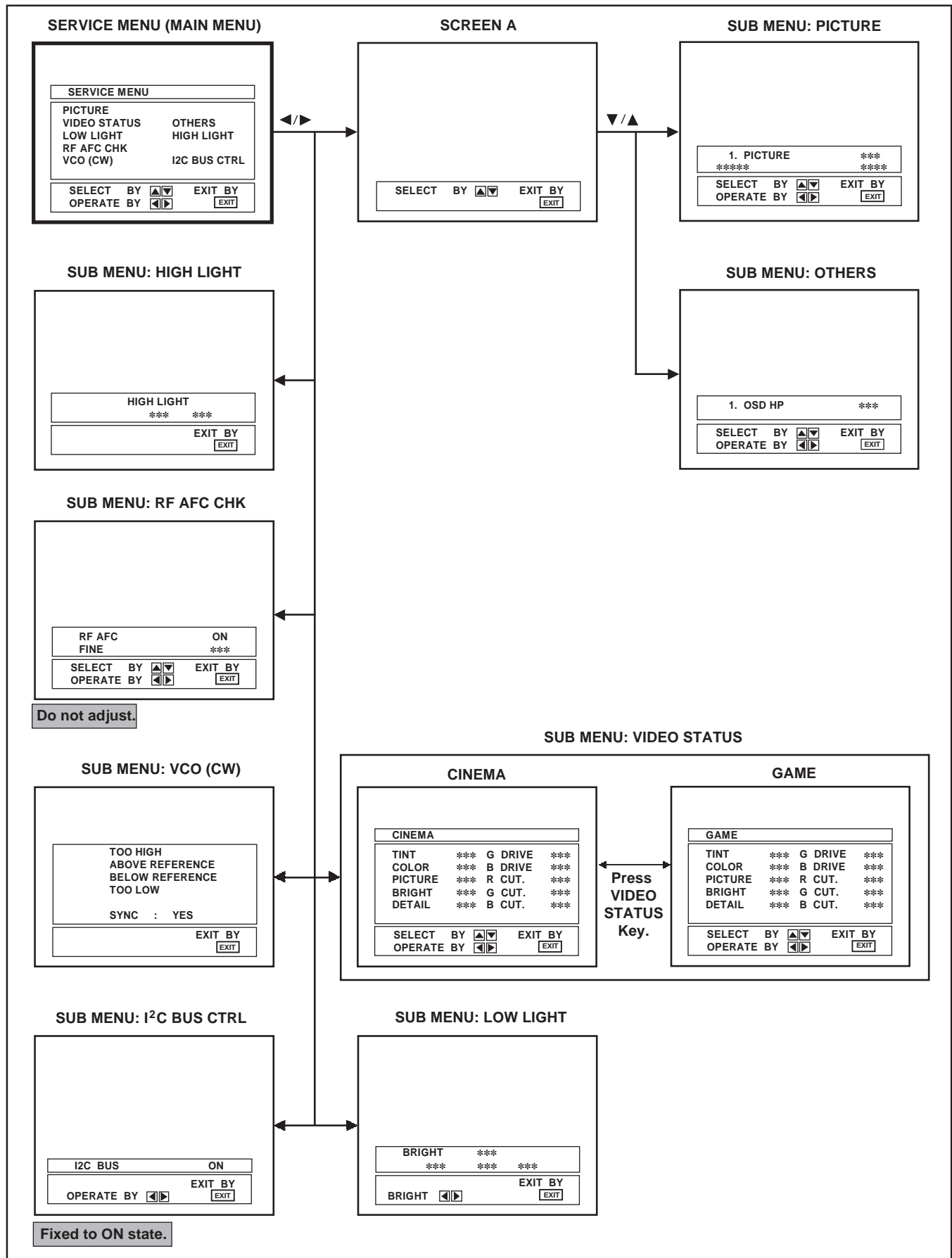
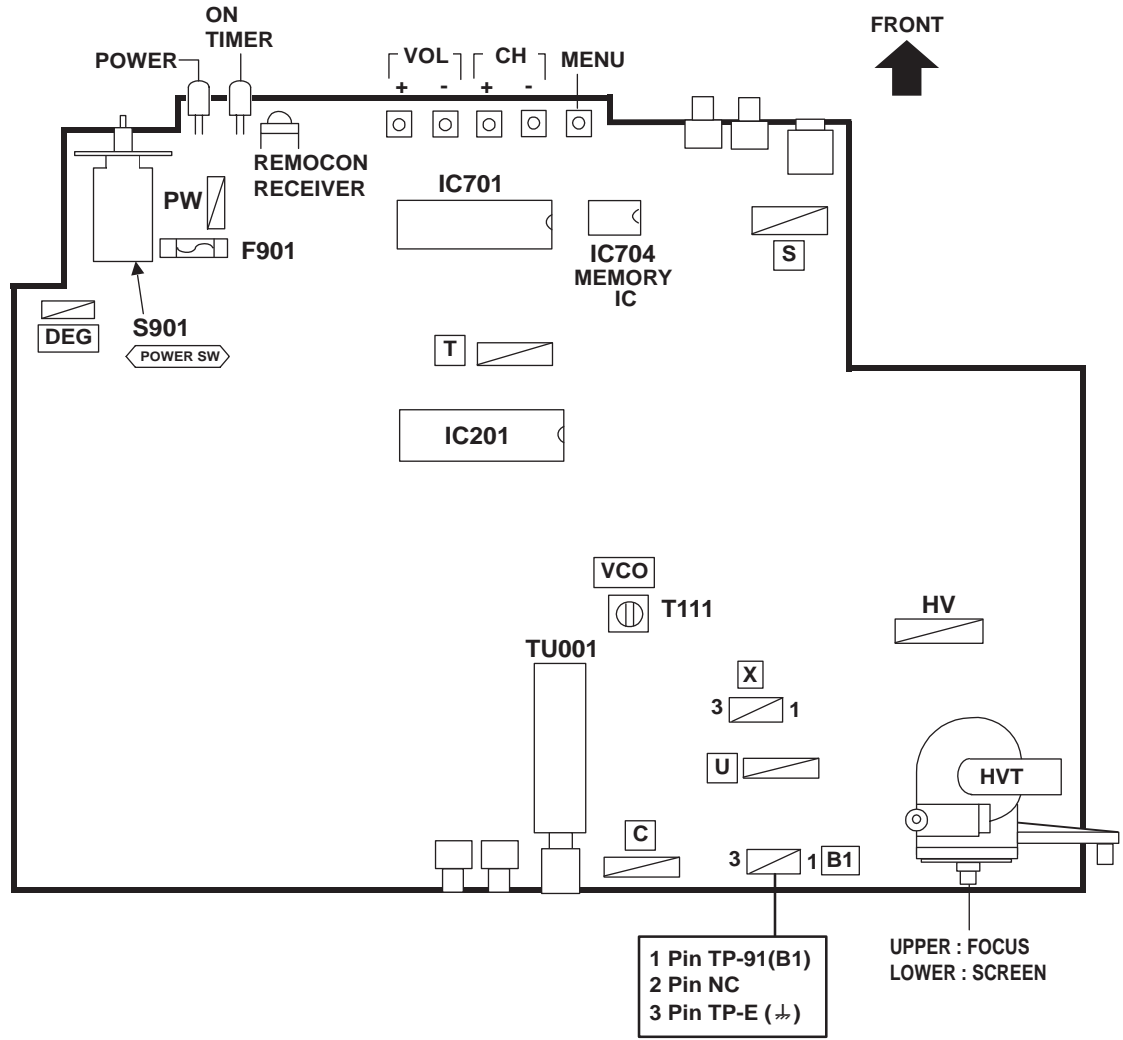

Fig. 3

ADJUSTMENT LOCATIONS

MAIN PWB



CRT SOCKET PWB (SOLDER SIDE)

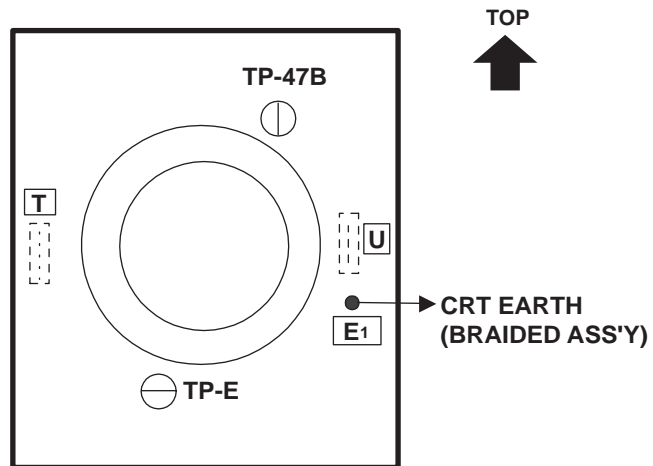

INITIAL SETTING VALUE OF SERVICE MENU

The setting (adjustment) using the remote control unit is made on the basis of the initial setting values.

The setting values which adjust the screen to the optimum condition can be different from the initial setting values.

● Do not change the initial setting values of the setting (adjustment) items not listed in "ADJUSTMENTS".

● PICTURE

★ The following four setting items in the video mode and TV mode are linked each other.

Video mode: 8. EXT PIC., 9. EXT BRI., 10. EXT COL. and 11. EXT TINT

TV mode: 1. PICTURE, 2. BRIGHT, 5. COL. NTSC and 6. TINT

When the setting items in the TV mode are adjusted, the same values will be set to the linking items in the video mode. For example, if the value of 1. PICTURE is changed, the value of 8. EXT PIC. will also be changed accordingly. (The initial setting values given in () are offset values against the TV mode.)

★ When the four items (Nos. 8, 9, 10 and 11) are adjusted in the video mode, the setting values will be changed independently from those in the TV mode.

Setting item	Variable range	Initial setting value
1. PICTURE	000 ~ 127	070
2. BRIGHT	000 ~ 127	064
3. COL. PALM	000 ~ 127	070
4. COL. PALN	000 ~ 127	070
5. COL. NTSC	000 ~ 127	072
6. TINT	000 ~ 127	065
7. TV DTL	000 ~ 063	033
8. EXT PIC.	±025	(±000)
9. EXT BRI.	±025	(+005)
10. EXT COL.	±025	(±000)
11. EXT TINT	±025	(+001)
12. EXT DTL	000 ~ 063	035
13. P/N KILL	000 / 001	001
14. Y S CONT	000 ~ 031	031
15. TV Y-DL	000 ~ 007	001
16. EXT Y-DL	000 ~ 007	002
17. WPL SW	000 / 001	000
18. Y GAMMA	000 / 001	000
19. P/N G P.	000 / 001	000
20. COL. L SW	000 / 001	001
21. COL. LMT.	000 ~ 003	001
22. PN C. ATT	000 ~ 003	001
23. OFST. SW	000 / 001	000
24. OFST. B-Y	000 ~ 015	008
25. OFST. R-Y	000 ~ 015	008
26. C-TOF SW	000 / 001	001
27. TV T FO	000 ~ 003	001
28. TV T Q	000 ~ 003	000
29. EXT T FO	000 ~ 003	000
30. EXT T Q	000 ~ 003	000

Settingitem	Variable range	Initial setting value
31. C-TRAP	000 / 001	000
32. C-TR. FO	000 ~ 003	002
33. C-TRAP Q	000 ~ 003	000
34. FIX B/W	000 / 001	000
35. APA P. FO	000 ~ 003	001
36. DC TRAN.	000 ~ 007	007
37. B. ST. SW	000 / 001	000
38. B. ST. PO.	000 ~ 007	000
39. ABL GAIN	000 ~ 007	004
40. ABL PO.	000 ~ 007	000
41. HALF T.	000 ~ 002	001
42. DRV G SW	000 / 001	000
43. NT. COMB	000 / 001	001
44. COIN DET	000 ~ 003	001
45. NOISE L.	000 ~ 003	003
46. VCD MODE	000 / 001	000
47. V AGC SP	000 / 001	000
48. H POS. 50	000 ~ 031	007
49. H BLK. 50	000 ~ 007	000
50. V POS. 50	000 ~ 007	000
51. V SIZE50	000 ~ 127	087
52. V S CR50	000 ~ 127	028
53. V LIN. 50	000 ~ 031	004
54. H POS. 60	000 ~ 031	012
55. H BLK. 60	000 ~ 007	000
56. V POS. 60	000 ~ 007	000
57. V SIZE60	000 ~ 127	088
58. V S CR60	000 ~ 127	048
59. V LIN. 60	000 ~ 031	004
60. RF AGC	000 ~ 255	160

: Do not adjust.

● VIDEO STATUS

Setting item	Variable range	Initial setting value	
		CINEMA	GAME
TINT	±20	±0	±0
COLOR	±20	-3	-3
PICTURE	±20	-10	-10
BRIGHT	±20	±0	±0
DETAIL	±15	±0	-5
G DRIVE	-99 ~ +50	-22	±0
B DRIVE	-99 ~ +50	-54	±0
R CUT.	±10	±0	±0
G CUT.	±10	±0	±0
B CUT.	±10	±0	±0

: Do not adjust.

● OTHERS

Setting item	Variable range	Initial setting value
1. OSD HP	000 ~ 063	023
2. OSD VP	000 ~ 015	012
3. H-CK SW	000 / 001	000

: Do not adjust.

● LOW LIGHT

Setting item	Variable range	Initial setting value
R CUTOFF	000 ~ 255	020
G CUTOFF	000 ~ 255	020
B CUTOFF	000 ~ 255	020

● HIGH LIGHT

Setting item	Variable range	Initial setting value
G DRIVE	000 ~ 255	128
B DRIVE	000 ~ 255	128

● RF AFC CHK

Setting item	Variable range	Initial setting value
RF AFC	ON / OFF	ON
FINE	-77 ~ +77	xx

: Do not adjust.

● I2C BUS CTRL

Setting item	Variable range	Initial setting value
I ² C BUS	ON / OFF	ON (Fixed to ON)

: Do not adjust.

ADJUSTMENTS

B1 POWER SUPPLY CHECK

Item	Measuring instrument	Test point	Adjustment part	Description
Check of B1 POWER SUPPLY	<ul style="list-style-type: none"> ● Signal Generator ● DC voltmeter 	B1 (TP-91) TP-E (↗) [B1 connector]		<ol style="list-style-type: none"> 1. Receive a black and white signal (color off). (NTSC) 2. Connect a DC voltmeter between B1 (TP-91) and TP-E (↗) (between pins 1 and 3 of the connector B1). 3. Make sure that the voltage is DC134.5 ± 2.0V.

IF VCO ADJUSTMENT

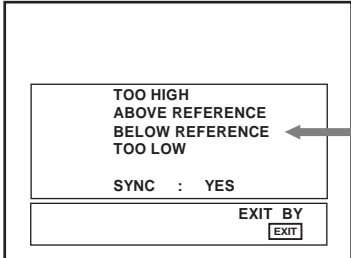
Item	Measuring instrument	Test point	Adjustment part	Description
Adjustment VCO (CW)	<ul style="list-style-type: none"> ● Signal Generator ● Remote control unit <p style="text-align: center;">SUB MENU: VCO (CW)</p>  <p style="text-align: center;">← YELLOW</p>		CW TRANSF. (T111) [MAIN PWB]	<ul style="list-style-type: none"> ● Under normal conditions, no adjustment is required. <ol style="list-style-type: none"> 1. Receive any broadcast. (Use a channel without offset frequency.) 2. Select the sub menu screen VCO (CW) from the SERVICE MENU. (More specifically, in the SERVICE MENU, press the MENU ▲/▼ key to select VCO (CW) and then press the MENU ◀/▶ key to enter the sub menu screen VCO (CW) .) 3. Confirm that the color of "TOO HIGH" and "TOO LOW" changes in yellow as you turn the CW TRANSF. At this time, check that "SYNC: YES" appears on the screen. 4. Slowly turn the CW TRANSF. until "BELOW REFERENCE" changes to yellow. Also, at this time, check that "SYNC: YES" appears on the screen. 5. Press the EXIT key to return to the normal screen.

RF AGC ADJUSTMENT

Item	Measuring instrument	Test point	Adjustment part	Description
Adjustment of RF AGC	Remote control unit		60. RF AGC	<ol style="list-style-type: none"> 1. Receive any broadcast. 2. Select the sub menu screen PICTURE from the SERVICE MENU. 3. Select 60. RF AGC with the MENU ▲/▼ key. 4. Press the MUTING key to turn off the color. 5. Press the MENU ◀ key to get noise on the screen picture. (The setting value will be decreased.) 6. Press the MENU ▶ key until noise disappears from the screen. 7. Change to other channels and make sure that there is no irregularity on the screen picture. 8. Press the MUTING key to turn on the color.

FOCUS ADJUSTMENT

Item	Measuring instrument	Test point	Adjustment part	Description
Adjustment of FOCUS	Signal generator		FOCUS VR [In HVT]	<ol style="list-style-type: none"> 1. Receive a cross-hatch signal. 2. While watching the screen, adjust the FOCUS VR to make the vertical and horizontal lines as fine and sharp as possible. 3. Make sure that, when the screen is darkened, the lines remain in good focus.

DEFLECTION CIRCUIT ADJUSTMENT

The setting (adjustment) using the remote control unit is made on the basis of the initial setting values shown on page 14.
 The setting values which adjust the screen to the optimum condition can be different from the initial setting values.
 ● Do not change the initial setting values of the setting (adjustment) items not listed herein.

Item	Measuring instrument	Test point	Adjustment part	Description
Adjustment of V. HEIGHT V. POSITION V. LIN. V. S CR	● Signal generator ● Remote control unit		56. V POS. 60 57. V SIZE60 58. V S CR60 59. V. LIN. 60	(60Hz) 1. Receive a cross-hatch signal. (NTSC or PAL-M) 2. Select the sub menu screen PICTURE from the SERVICE MENU. 3. Select 56. V POS. 60 with the MENU ▲/▼ key, and confirm that the setting value is 0. NOTE: The value of 56. V POS. 60 should be fixed to 0. 4. Confirm the initial setting value of 57. V SIZE60 , 58. V S CR60 , and 59. V. LIN. 60 . 5. Adjust 57. V SIZE60 and make the vertical screen size 92% of the picture size, with the MENU ◀/▶ key. 6. Adjust 59. V. LIN. 60 and 58. V S CR60 to get the best vertical linearity, with the MENU ◀/▶ key.
			50. V POS. 50 51. V SIZE50 52. V S CR50 53. V. LIN. 50	(50Hz) 1. Receive a cross-hatch signal. (PAL-N) 2. In the sub menu screen PICTURE , select 50. V POS. 50 , 51. V SIZE50 , 52. V S CR50 , and 53. V. LIN. 50 with the MENU ▲/▼ key, and confirm their initial setting values. 3. Adjust 51. V SIZE 50 and make the vertical screen size 92% of the picture size, with the MENU ◀/▶ key. 4. Adjust 53. V. LIN. 50 and 52. V S CR50 to get the best vertical linearity, with the MENU ◀/▶ key. 5. Adjust 50. V POS. 50 so that the vertical center line comes close to the CRT vertical center as much as possible, with the MENU ◀/▶ key. ● Readjust V SIZE, V. LIN, V S CR if necessary.
Adjustment of H. POSITION	● Signal generator ● Remote control unit		54. H POS.60	(60Hz) 1. Receive a cross-hatch signal. (NTSC or PAL-M) 2. Select the sub menu screen PICTURE from the SERVICE MENU. 3. Select 54. H POS.60 with the MENU ▲/▼ key. 4. Confirm the initial setting value of 54. H POS.60 . 5. Adjust 54. H POS.60 so that the screen will be horizontally centered, with the MENU ◀/▶ key.
			48. H POS.50	(50Hz) 1. Receive a cross-hatch signal. (PAL-N) 2. In the sub menu screen PICTURE , select 48. H POS.50 with the MENU ▲/▼ key. 3. Confirm the initial setting value of 48. H POS.50 . 4. Adjust 48. H POS.50 so that the screen will be horizontally centered, with the MENU ◀/▶ key.

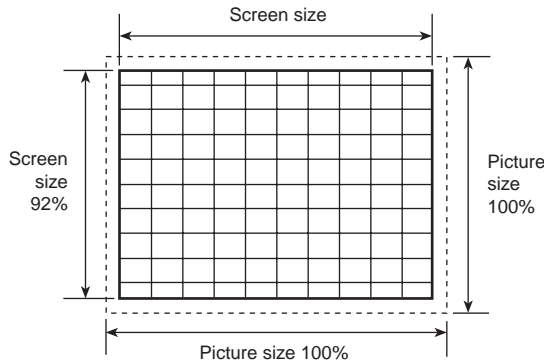

VIDEO/CHROMA CIRCUIT ADJUSTMENT

The setting (adjustment) using the remote control unit is made on the basis of the initial setting values shown on pages 14 and 15.

The setting values which adjust the screen to the optimum condition can be different from the initial setting values.

● Do not change the initial setting values of the setting (adjustment) items not listed herein.

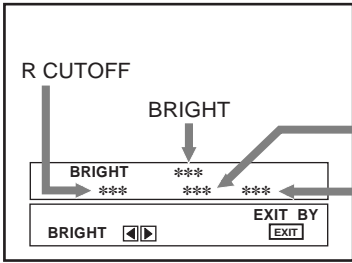
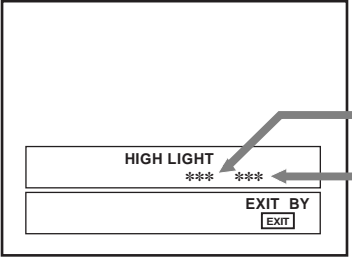
Item	Measuring instrument	Test point	Adjustment part	Description
<p>Adjustment of WHITE BALANCE (Low light)</p>	<ul style="list-style-type: none"> ● Signal generator ● Remote control unit 		<p>BRIGHT</p> <p>R CUTOFF</p> <p>G CUTOFF</p> <p>B CUTOFF</p> <p>SCREEN VR (In HVT)</p>	<ol style="list-style-type: none"> 1. Receive a black and white signal (color off). 2. Select the sub menu screen LOW LIGHT from the SERVICE MENU. 3. Confirm that the value of BRIGHT, R CUTOFF, G CUTOFF, and B CUTOFF is set to the initial setting value. 4. Press the 1 key on the remote control unit to produce a single horizontal line. 5. Turn the SCREEN VR fully counterclockwise, then slowly turn it clockwise to where a red, blue, or green color is faintly visible. 6. Use keys 4 ~ 9 on the remote control unit and adjust the other 2 colors to where the single horizontal line becomes white. 7. Turn the SCREEN VR to where the single horizontal line glows faintly. 8. Press the 2 key to stop producing a single horizontal line. <p>NOTE: The key 3 acts in the same way as the EXIT key.</p> <div style="text-align: center;"> <p>SUB MENU: LOW LIGHT</p>  </div>
<p>Adjustment of WHITE BALANCE (High light)</p>	<ul style="list-style-type: none"> ● Signal generator ● Remote control unit 		<p>G DRIVE</p> <p>B DRIVE</p>	<ol style="list-style-type: none"> 1. Receive a black and white signal (color off). 2. Select the sub menu screen HIGH LIGHT from the SERVICE MENU. 3. Confirm that the value of G DRIVE and B DRIVE is set to the initial setting value. 4. Use the keys 5 and 8 or 6 and 9 to produce a white screen. <p>NOTE: The key 3 acts in the same way as the EXIT key.</p> <div style="text-align: center;"> <p>SUB MENU: HIGH LIGHT</p>  </div>

Item	Measuring instrument	Test point	Adjustment part	Description
Adjustment of SUB BRIGHT	Remote control unit		2. BRIGHT	<ol style="list-style-type: none"> 1. Receive any broadcast. 2. Select the sub menu screen PICTURE from the SERVICE MENU. 3. Select 2. BRIGHT with the MENU ▲/▼ key, and confirm its initial setting value. 4. If the brightness is not the best with the initial set value, make fine adjustment until you get the best brightness, with the MENU ◀/▶ key.
Adjustment of SUB CONT.	Remote control unit		1. PICTURE	<ol style="list-style-type: none"> 1. Receive any broadcast. 2. Select the sub menu screen PICTURE from the SERVICE MENU. 3. Select 1. PICTURE with the MENU ▲/▼ key, and confirm its initial setting value. 4. If the contrast is not the best with the initial set value, make fine adjustment until you get the best contrast, with the MENU ◀/▶ key.
Adjustment of SUB COLOR -I	Remote control unit			[Method of adjustment without measuring instrument]
			3. COL. PALM	(PAL-M COLOR) <ol style="list-style-type: none"> 1. Receive a PAL-M broadcast. 2. Select the sub menu screen PICTURE from the SERVICE MENU. 3. Select 3. COL. PALM with the MENU ▲/▼ key, and confirm its initial setting value. 4. If the color is not the best with the initial set value, make fine adjustment until you get the best color, with the MENU ◀/▶ key.
			4. COL. PALN	(PAL-N COLOR) <ol style="list-style-type: none"> 1. Receive a PAL-N broadcast. 2. In the sub menu screen PICTURE, select 4. COL. PALN with the MENU ▲/▼ key, and confirm its initial setting value. 3. If the color is not the best with the initial set value, make fine adjustment until you get the best color, with the MENU ◀/▶ key.
			5. COL. NTSC	(NTSC COLOR) <ol style="list-style-type: none"> 1. Receive a NTSC broadcast. 2. In the sub menu screen PICTURE, select 5. COL. NTSC with the MENU ▲/▼ key, and confirm its initial setting value. 3. If the color is not the best with the initial set value, make fine adjustment until you get the best color, with the MENU ◀/▶ key.

Item	Measuring instrument	Test point	Adjustment part	Description
Adjustment of SUB COLOR-II	<ul style="list-style-type: none"> ● Signal generator ● Oscilloscope ● Remote control unit 	TP-47B TP-E (↗) [CRT SOCKET PWB]		[Method of adjustment using measuring instrument]
			3. COL. PALM	(PAL-M COLOR) 1. Receive a PAL-M full field color bar signal (75% white). 2. Select the sub menu screen PICTURE from the SERVICE MENU. 3. Select 3. COL. PALM with the MENU ▲/▼ key, and confirm its initial setting value. 4. Connect the oscilloscope between TP-47B and TP-E. 5. Adjust 3. COL. PALM to set the value (A) in the figure to +11V (W & B) , with the MENU ◀/▶ key.
			4. COL. PALN	(PAL-N COLOR) 1. Receive a PAL-N full field color bar signal (75% white). 2. In the sub menu screen PICTURE , select 4. COL. PALN with the MENU ▲/▼ key, and confirm its initial setting value. 3. Connect the oscilloscope between TP-47B and TP-E. 4. Adjust 4. COL. PALN to set the value (A) in the figure to +10V (W & B) , with the MENU ◀/▶ key.
5. COL. NTSC	(NTSC COLOR) 1. Receive a NTSC full field color bar signal (75% white). 2. In the sub menu screen PICTURE , select 5. COL. NTSC with the MENU ▲/▼ key, and confirm its initial setting value. 3. Connect the oscilloscope between TP-47B and TP-E. 4. Adjust 5. COL. NTSC to set the value (A) in the figure to +10V (W & B) , with the MENU ◀/▶ key.			
Adjustment of SUB TINT-I	<ul style="list-style-type: none"> ● Signal Generator ● Remote control unit 		6. TINT	[Method of adjustment without measuring instrument] 1. Receive a NTSC color bar signal. 2. Select the sub menu screen PICTURE from the SERVICE MENU. 3. Select 6. TINT with the MENU ▲/▼ key, and confirm its initial setting value. 4. If the tint is not the best with the initial set value, make fine adjustment until you get the best tint, with the MENU ◀/▶ key.

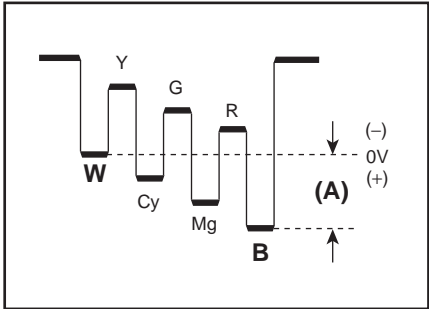

Item	Measuring instrument	Test point	Adjustment part	Description
Adjustment of SUB TINT-II	<ul style="list-style-type: none"> ● Signal generator ● Oscilloscope ● Remote control unit 	TP-47B TP-E (↘) [CRT SOCKET PWB]	6. TINT	<p>[Method of adjustment using measuring instrument]</p> <ol style="list-style-type: none"> 1. Receive a NTSC 3.58 color bar signal (full field color bar 75% white). 2. Select the sub menu screen PICTURE from the SERVICE MENU. 3. Select 6. TINT with the MENU ▲/▼ key, and confirm its initial setting value. 4. Connect the oscilloscope between TP-47B and TP-E. 5. Adjust 6. TINT to set the value (B) in the figure to +14V (W & Mg), with the MENU ◀▶ key.

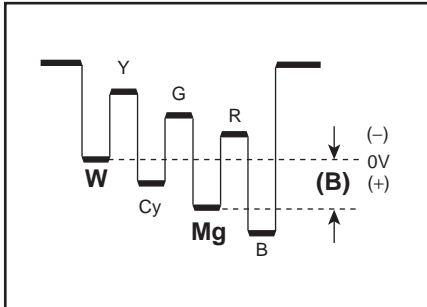

VIDEO STATUS ADJUSTMENT

Item	Measuring instrument	Test point	Adjustment part	Description
Setting of VIDEO STATUS	Remote control unit		TINT COLOR PICTURE BRIGHT DETAIL G DRIVE B DRIVE R CUT. G CUT. B CUT.	<p>NOTE: Do not adjust. Each value should be set to the initial value.</p> <ol style="list-style-type: none"> 1. Select the sub menu screen VIDEO STATUS-CINEMA from the SERVICE MENU. 2. Select TINT ~ B CUT. with the MENU ▲/▼ key, and reset each value to the initial setting value on page 15, with the MENU ◀▶ key. 3. Press the VIDEO STATUS key on the remote control unit to select VIDEO STATUS-GAME. (Each time you press the VIDEO STATUS key, CINEMA and GAME alternates.) 4. Make similar settings as in 2 above.

SUB MENU: VIDEO STATUS

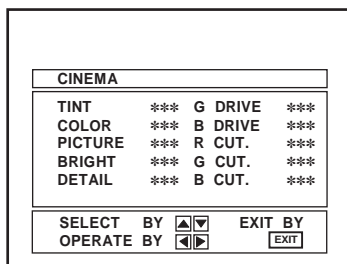

■ X-RAY PROTECTION CHECK

Item	Measuring instrument	Test point	Adjustment part	Description
<p>Check of X-RAY PROTECTION</p>		<p>Pins 1 and 3 [X Connector on MAIN PWB]</p>		<p>● Prepare the following resistor. 17.2kΩ ±1% 1/4W</p> <ol style="list-style-type: none"> 1. Turn on the power and receive any signal. 2. Connect the resistor between pins 1 and 3 of the X connector on the Main PW Board. 3. Make sure that the picture disappears. 4. Unplug the AC power cord. 5. Disconnect the resistor from the X connector. 6. Plug the AC power cord and make sure that the picture appears normally. <p>X-Ray Protector Operation: Normally the voltage at point "A" does not exceed the Zener voltage of D562. (The voltage at point "A" will be determined by dividing the voltage from HVT (FBT) by R562 and R563.) When you connect a resistor of 17.2kΩ or less in parallel with R562, the voltage at point "A" is increased, D562 turns ON, and the X-ray protection circuit is activated. Once it is activated, you need to unplug the AC power cord to restore the X-ray protection circuit.</p>

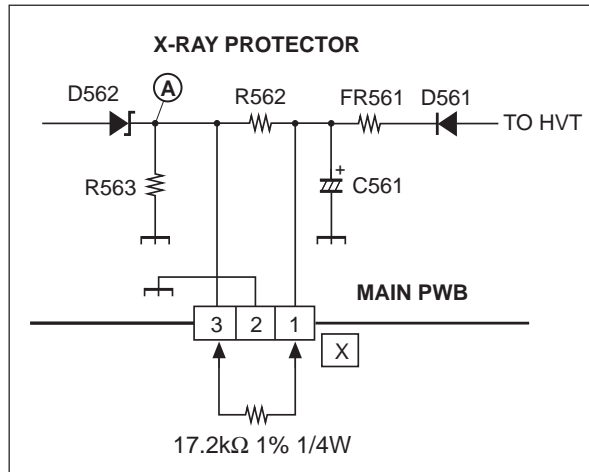

PURITY, CONVERGENCE ADJUSTMENT

PURITY ADJUSTMENT

1. Demagnetize CRT with the demagnetizer.
2. Loosen the retainer screw of the deflection yoke.
3. Remove the wedges. (Fig. 1.)
4. Input a green raster signal from the signal generator, and turn the screen to green raster.
5. Move the deflection yoke backward.
6. Bring the long lug of the purity magnets on the short lug and position them horizontally. (Fig. 2)
7. Adjust the gap between two lugs so that the green raster will come into the center of the screen. (Fig. 3)
8. Move the deflection yoke forward, and fix the position of the deflection yoke so that the whole screen will become green.
9. Insert the wedge to the top side of the deflection yoke so that it will not move.
10. Input a cross-hatch signal.
11. Verify that the screen is horizontal.
12. Input red and blue raster signals, and make sure that purity is properly adjusted.

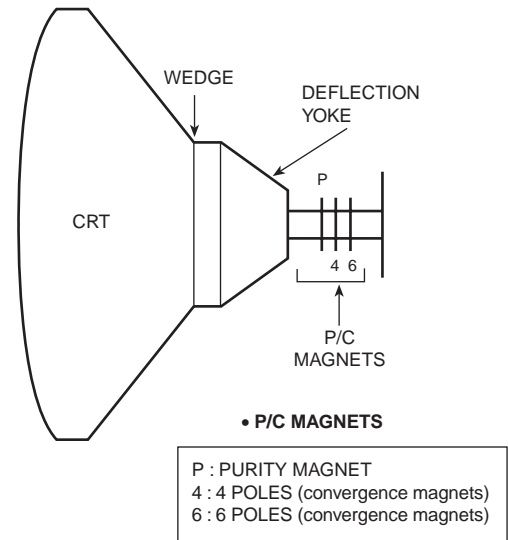

Fig. 1

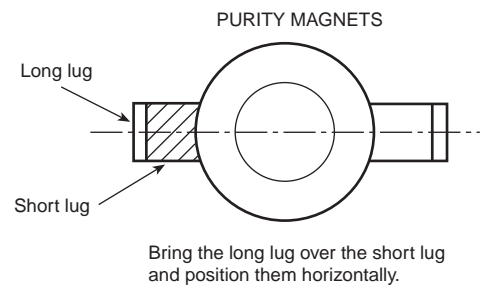

Fig. 2

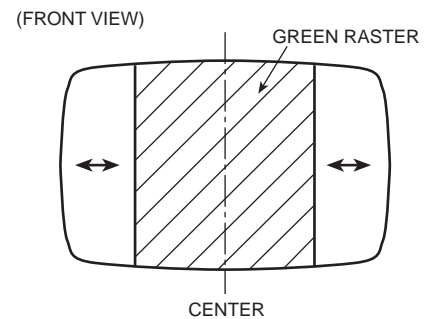

Fig. 3

STATIC CONVERGENCE ADJUSTMENT

1. Input a cross-hatch signal.
2. Using 4-pole convergence magnets, overlap the red and blue lines in the center of the screen (Fig. 1) to turn them to magenta (red/blue).
3. Using 6-pole convergence magnets, overlap the magenta (red/blue) and green lines in the center of the screen to turn them to white.
4. Repeat 2 and 3 above, and make best convergence.

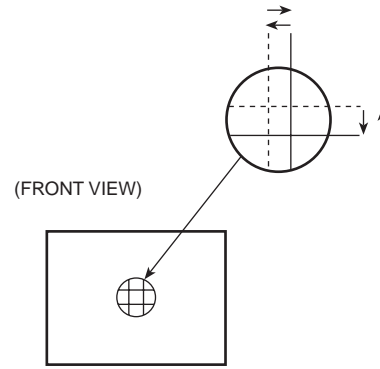

Fig. 1

DYNAMIC CONVERGENCE ADJUSTMENT

1. Move the deflection yoke up and down and overlap the lines in the periphery. (Fig. 2)
 2. Move the deflection yoke left to right and overlap the lines in the periphery. (Fig. 3)
 3. Repeat 1 and 2 above, and make best convergence.
- After adjustment, fix the wedge at the original position. Fasten the retainer screw of the deflection yoke. Fix the 6 magnets with glue.

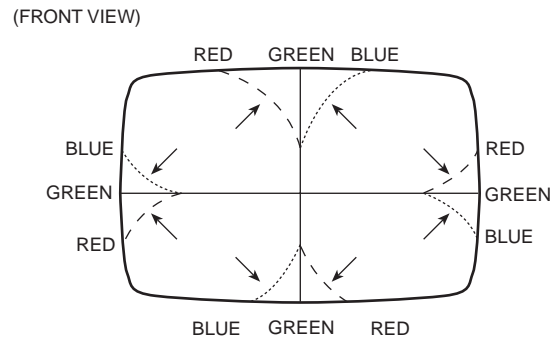

Fig. 2

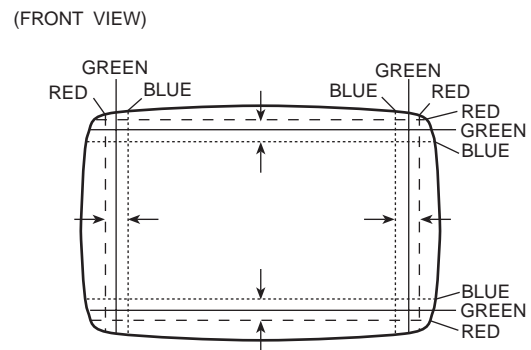

Fig. 3

SELF-CHECK FUNCTIONS

1. Outline

This model has self-check functions given below. When an abnormality has been detected, the SUB POWER is turned off and the ON TIMER LED flashes to inform of the failure. An abnormality is detected by the signal input state of the control line connected to the microcomputer.

2. Self-check items

Check item	Details of detection	Method of detection	State of abnormality
Over-current protection	An over-current on the low B line is detected. Also, an over-current for speaker drive is detected.	The microcomputer detects the possible abnormality at 1-sec. intervals. If NG state is detected for more than 1 ms, the microcomputer judges that there is an abnormality.	When an abnormality has been detected, the SUB-POWER is turned off. While the SUB-POWER is being turned off, the POWER key on the remote control unit is not operational until the power cord is taken out and put in again.
CRT NECK protection	Operation of CRT NECK protection circuit	DITTO	DITTO
X-ray protection	Operation of X-ray protection circuit.	DITTO	DITTO

3. Self-check indicating function

When an abnormality has been detected at about 5 seconds after the power is turned on, the SUB POWER is turned off immediately and the ON TIMER LED flashes.

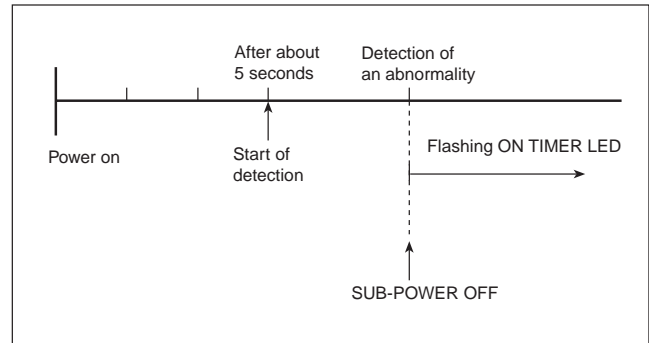

[Indication by the LED]

Item	LED flashing intervals	Priority of detection
Over-current protection/X-ray protection	At 0.5-second intervals	1
CRT NECK protection	At 1-second intervals	2



JVC

VICTOR COMPANY OF JAPAN, LIMITED
TELEVISION RECEIVER DIVISION 1106 Heta, Iwai-city, Ibaraki-prefecture, 306-0698, Japan

